

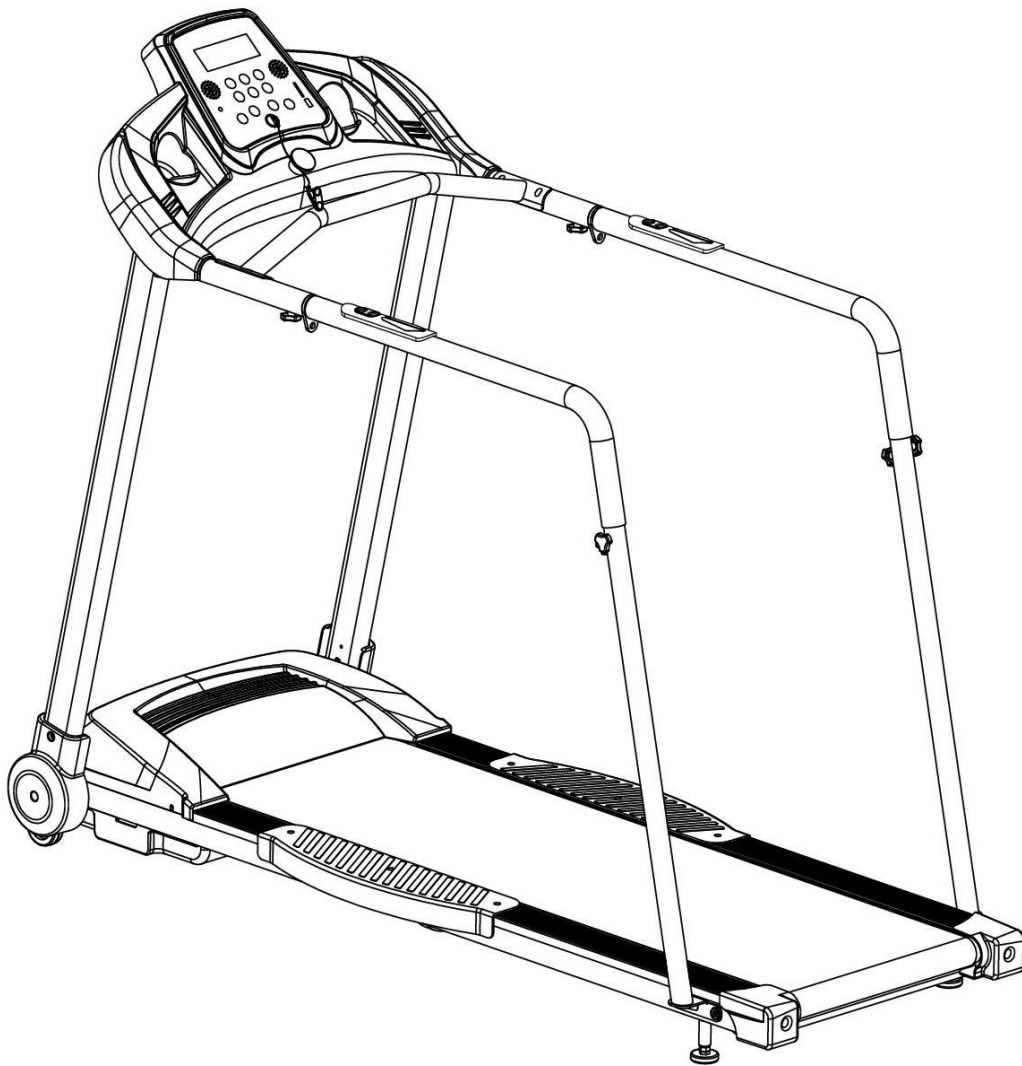

USER MANUAL – EN

IN 13080 Motorized Treadmill inSPORTline Neblin



CONTENTS

- SAFETY INSTRUCTIONS..... 3
 - IMPORTANT ELECTRICAL INFORMATION 4
 - IMPORTANT OPERATION INSTRUCTIONS 4
- ASSEMBLY INSTRUCTIONS 5
- ASSEMBLY STEPS 6
- GROUNDING METHODS 9
- OPERATION GUIDE 10
 - WINDOW DISPLAY 10
 - BUTTON FUNCTIONS 11
- EXERCISE INSTRUCTIONS 11
- MAINTENANCE 12
 - BELT/DECK/ROLLER LUBRICATION 14
 - TIGHTENING THE BELT/POLY V-BELT 15
- EXPLODED DRAWING..... 17
- PARTS LIST 18
- TROUBLE SHOOTING 20
- TERMS AND CONDITIONS OF WARRANTY, WARRANTY CLAIMS..... 21

Special tips:

1. Before installation and operation, please read this operation manual carefully.
2. Please save this manual for future reference.
3. Product may vary slightly from the item pictured due to model upgrades.

SAFETY INSTRUCTIONS

WARNING – Read all instructions before using this treadmill. It is important your treadmill receives regular maintenance, you can further its longevity this way. Failing to regularly maintain your treadmill may void your warranty.

Danger: To reduce the risk of electric shock, disconnect your treadmill from the electrical outlet prior to cleaning and/or service work.

DO NOT USE AN EXTENSION CORD. DO NOT ATTEMPT TO DISABLE THE GROUNDED PLUG BY USING IMPROPER ADAPTERS OR IN ANY WAY MODIFY THE CORD SET.

- 1) Install the treadmill on a flat level surface with access to correct voltage and frequency and a grounded outlet.
- 2) Do not operate the treadmill on deeply padded, plush or shag carpet. You may damage both the carpet and the treadmill.
- 3) Do not block the rear of the treadmill. Provide a minimum of 0.6 meter clearance between the rear of the treadmill and any fixed object.
- 4) Place your unit on a solid, level surface when in use.
- 5) Never allow children on or near the treadmill.
- 6) When running, make sure the plastic clip is fastened to your clothing. It is for your safety, should you fall or move too far back on the treadmill.
- 7) Keep hands away from all moving parts.
- 8) Never operate the treadmill if it has a damaged cord or a plug.
- 9) Keep the cord away from heated surfaces.
- 10) Do not operate where aerosol spray products are being used or where oxygen is being administered. Sparks from the motor may ignite in a highly flammable environment.
- 11) Never drop or insert any objects into any openings.
- 12) No adjustable part should be protruding for it could limit the user's range of movement.
- 13) The treadmill is intended for in-home use only and not suitable for long time running.
- 14) To disconnect, turn all controls to the off position, remove the safety key, and then remove the plug from the outlet.
- 15) The pulse sensors are not medical devices. Various factors, including the user's movement, may affect the accuracy of heart rate readings. The pulse sensors are intended only as exercise aids in determining heart rate trends in general.
- 16) Use the handrails; they are for your safety.
- 17) Wear proper shoes. High heels, dress shoes, sandals or bare feet are not suitable for use on your treadmill. Quality athletic shoes are recommended to avoid leg fatigue.
- 18) Allowed temperature: 5 to 40°C.
- 19) **Weight limit:** 120 kg
- 20) **Category:** HA (according to EN957 norm) suitable for home use
- 21) **WARNING!** The heart rate frequency monitoring may not be completely accurate. Overexertion during training can lead to a serious injury or even death. If you start to feel faint, stop the exercise immediately.

Remove the safety key after use to prevent unauthorized treadmill operation.

IMPORTANT ELECTRICAL INFORMATION

WARNING!





















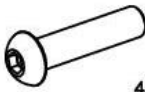



- 1) NEVER use a ground fault circuit interrupt (GFCI) wall outlet with this treadmill. Route the power cord away from any moving parts of the treadmill including the elevation mechanism and transport wheels.
- 2) NEVER operate treadmill on generator or UPS power supply.
- 3) NEVER remove any cover without first disconnecting AC power.
- 4) NEVER expose this treadmill to rain or moisture. This treadmill is not designed for use outdoors, near a pool, or in any other high humidity environment.

IMPORTANT OPERATION INSTRUCTIONS

- 1) Insert the power plug into the socket directly.
- 2) The constant running time is less than 2 hours. Be sure to read the entire manual before operating your machine.
- 3) Understand that changes in speed and incline do not occur immediately. Set your desired speed on the computer console and release the adjustment key. The computer will obey the command gradually.
- 4) Use caution while participating in other activities while walking on your treadmill; such as watching television, reading, etc. These distractions may cause you to lose balance or stray from walking in the centre of the belt; which may result in serious injury.
- 5) In order to prevent losing balance and suffering unexpected injury, NEVER mount or dismount the treadmill while the belt is moving.
- 6) This unit starts with a very low speed. Simply standing on the belt during slow acceleration is proper after you have learned to operate this machine.
- 7) Always hold on to handrail while making control changes.
- 8) A safety key is provided with this machine. Removing the safety key will stop the walking belt immediately; the treadmill will shut down automatically. Inserting the safety key will reset the display.
- 9) Do not use excessive pressure on console control keys. They are set to function properly with little finger pressure.
- 10) This appliance is not intended for use by persons (including children) with reduced physical, sensory or mental capabilities, or lack of experience and knowledge, unless they have been given supervision or instruction concerning the use of the appliance by a person responsible for their safety. Children should be supervised to ensure that they do not play with the appliance.
- 11) Please consult your doctor at first before running, if one of the following terms apply to you:
 - a. Cardiomyopathy, hypertension, sugar diabetes, respiratory disease, smoking, and other chronic diseases.
 - b. If you are over 35 years old and heavier than common weight.
 - c. Pregnant or breastfeeding women.
- 12) Please stop exercising immediately and consult your doctor when you feel faint or surfeit, you have a thorax ache or other symptoms.
- 13) Please drink adequate amount of water after exercising on our treadmill for more than 20 minutes.

Warning: We suggest that you consult your physician or health professional before starting your workout, especially if you are over 35 years old or have a health problem. We take no responsibility for any troubles or hurts if you don't follow our specification. The treadmill needs to be carefully assembled and the motor shield covered. Only then connect the treadmill to the power supply.

ASSEMBLY INSTRUCTIONS

 2	 55	 39	 11	 12	 45
 7	 8	 75	 33	 34	 44
 28	 1	 79	 80	 81	 82
 85	 84	 41	 56	 57	 49
 66	 CC				

PARTS LIST:

NO.	DESCRIPTION	SPECIFICATION	QTY.
2	MAIN FRAME		1
39	BOLT	M8*15	8
12	5# ALLEN WRENCH	5 mm	1
7	LEFT FOOT PEDAL		1
75	BOLT	M5*12	4
34	RIGHT SIDE COVER		1
28	NUT	M8	4
79	LEFT HANDLEBAR		1
81	LEFT SUPPORT TUBE		1
85	TRIANGLE KNOB	M6*10	6
41	BOLT	M8*25	4
57	WASHER	8	4
66	SAFETY KEY		1
55	LOCK WASHER	8	8
11	WRENCH W/ SCREW DRIVER	S=13, 14, 15	1
45	SCREW	ST4.2*15	6

8	RIGHT FOOT PEDAL		1
33	LEFT SIDE COVER		1
44	BOLT	M8*50	4
1	CONNECTING TUBE		1
80	RIGHT LEFT HANDLEBAR		1
82	RIGHT SUPPORT TUBE		1
84	HOOK		2
56	SPRING WASHER	8	4
49	ARC WASHER	8	8
CC	LUBRICATION OIL		1

Assembly tools:

5# Allen wrench 5 mm – 1pc

Wrench with screw driver S=13, 14, 15 – 1pc

Notice: Do not connect to the power supply before complete assembly.

ASSEMBLY STEPS

STEP 1:

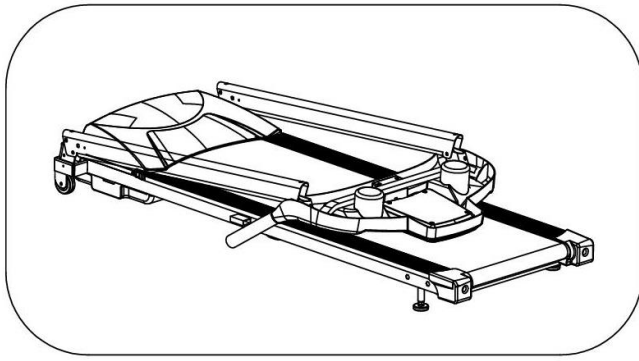
	<p>Open the carton, and remove all the parts from the box carefully.</p>
---	--

STEP 2:

	<p>Lift up the console (B) in the direction indicated by the arrows.</p> <p>Note: Be careful when putting the console in place. There are wires running through the uprights when lifting please ensure the wire is not being pinched. Hold the uprights to prevent the console falling until it has been secured as per step 3.</p>
---	--

STEP 3:

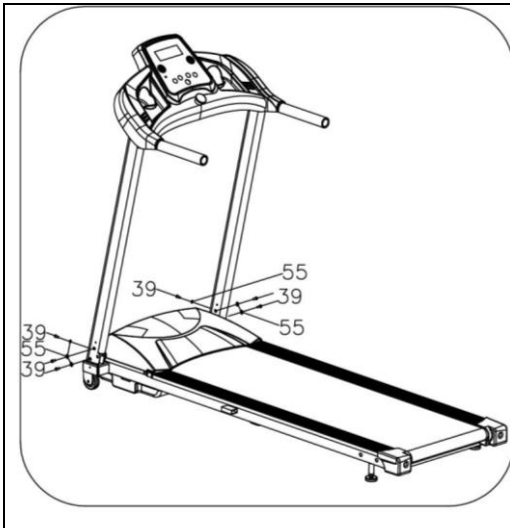

Use the 5# Allen wrench and M8*15 bolts (39) and lock washers (55) to lock the upright tubes onto the main frame.

Notice: Support the upright tubes so that they don't fall down.

STEP 4:



Use the 5# Allen wrench and M8*15 bolts (39) and lock washers (55) to lock the console (B) onto the left and right upright tube.

STEP 5:

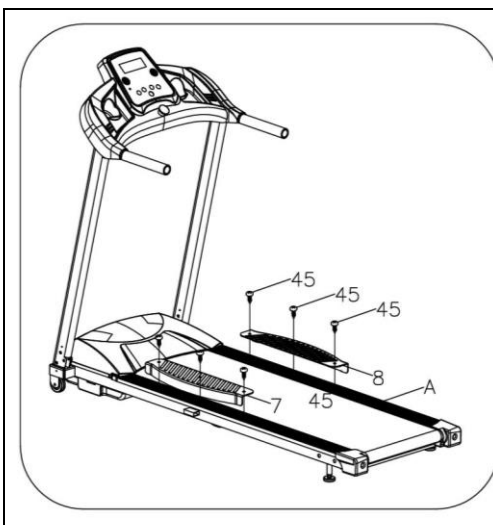

Fix the left and right foot pedals (7, 8) to the main frame with screws ST4.2*15 (45).

STEP 6:

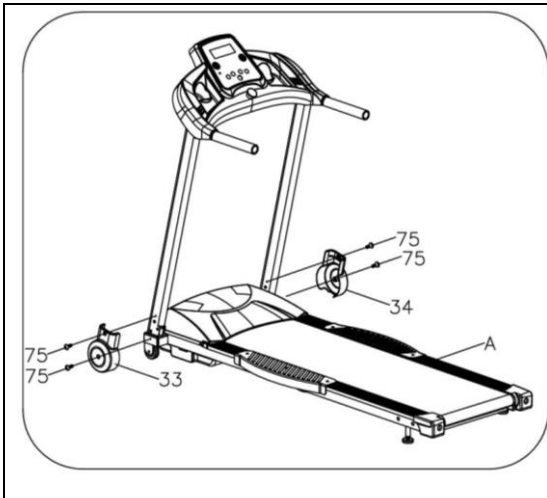

Fix the left & right side covers (33, 34) to the base frame with bolts M5*12 (75).

STEP 7:

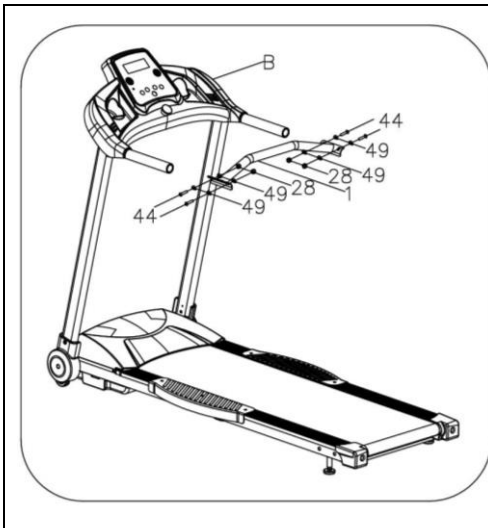

Fix the connecting tube (1) to the console handle bar with bolts M8*50 (44), arc washers (49) and nuts (28).

STEP 8:

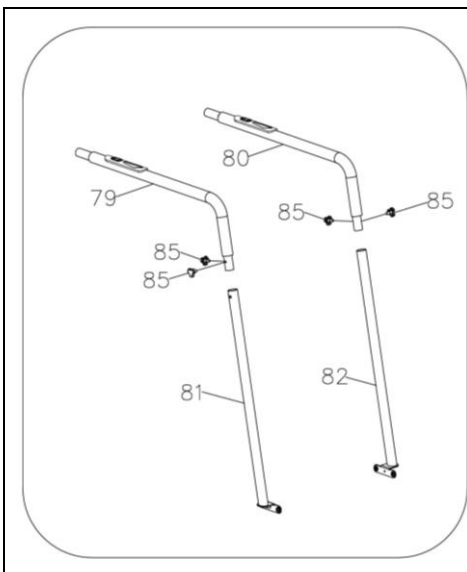

Connect the left handlebar (79) with the left support tube (81) and the right handlebar (80) with the right support tube (82) by using triangle knobs M6*10 (85).

Note: Don't mix the parts of left and right handlebar.

STEP 9:

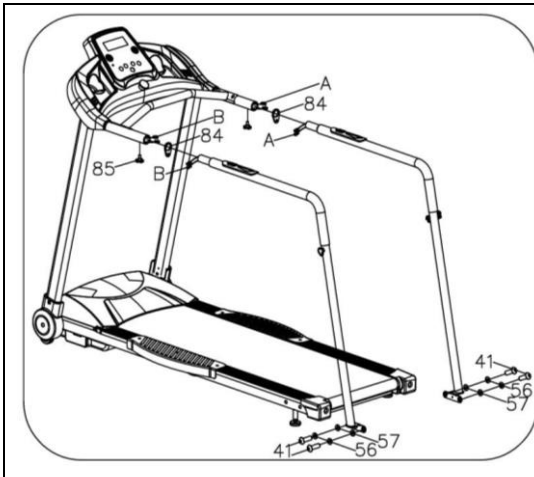

1. Connect the wires of hand pulse with speed (A), and hand pulse with start/stop (B) first.
2. Insert the hooks (84) on the handlebars (79, 80) first, then fix the left and right handlebar assembly to the console with triangle knob M6*10 (85).
3. Fix the left and right handlebar assembly (79, 80) to the base frame with bolt M8*25 (41), spring washer (56) and flat washer (57.)

STEP 10:



Attach the safety key (66) to the magnet part (A).

GROUNDING METHODS

This product must be grounded. If it should malfunction or breakdown, grounding provides a path of least resistance for electric current to reduce the risk of electric shock. This product is equipped with a cord having an equipment-grounding conductor and a grounding plug. The plug must be plugged into an appropriate outlet that is properly installed and grounded in accordance with all local laws and ordinances.

DANGER – Improper connection of the equipment-grounding conductor can result in a risk of electric shock. Check with a qualified electrician or serviceman if you are in doubt as to whether the product is properly grounded. Do not modify the plug provided with the product – if it will not fit the outlet, have a proper outlet installed by a qualified electrician.

This product is for use on a nominal voltage circuit (220 V) and has a grounding plug that looks like the plug illustrated in sketch A in the following figure. Make sure that the product is connected to an outlet with the same configuration as the plug. Do not use an adapter.

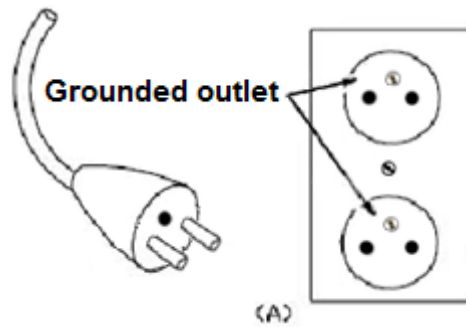

OPERATION GUIDE

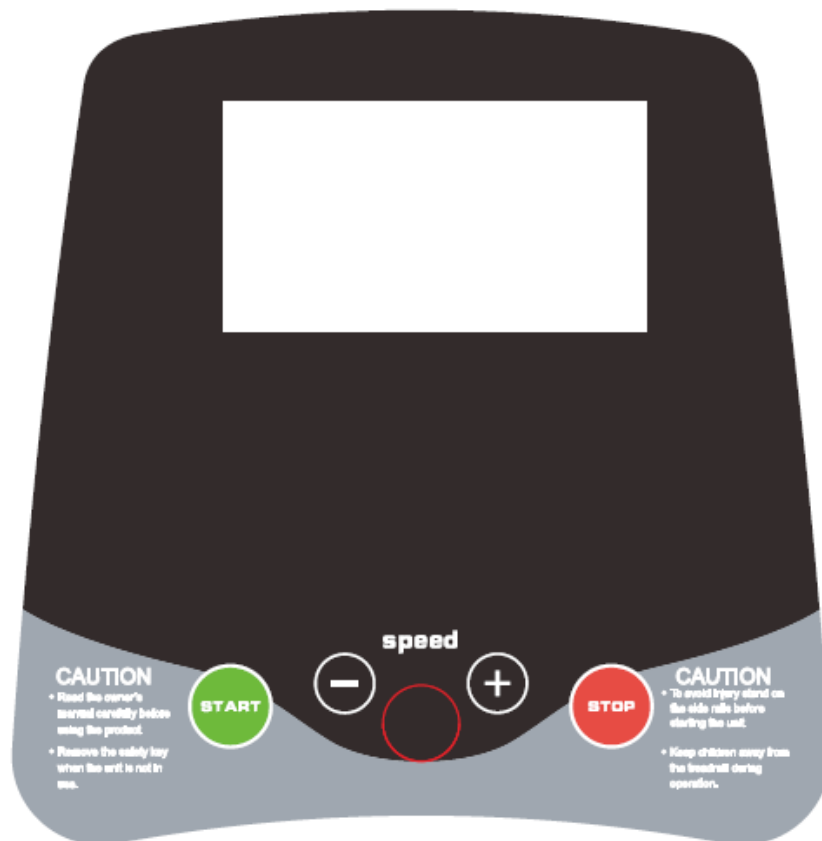

WINDOW DISPLAY

SPEED: Displays the speed in the range of 0.3 - 6 km/h.

TIME: Displays running time.

In modes where a target time has not been specifically set, the display will count up from 0:00 to 99:59 minutes. If the count reaches 99:59 the machine will turn off by slowing the belt smoothly, and the console will return to its initial state.

DISTANCE: The window will show the distance in km, counting up from 0.00 to 99.9 km. When 99.9 is reached, the machine will stop smoothly, show 'End' on the display and enter into its initial state after another 5 seconds.

CALORIES: Displays the amount of calories the runner has burned in the range of 0 to 999 CAL. When a count of 999 has been reached it will start again from 0.

PULSE: Displays the runner's heartbeat in the range of 50 – 200 bpm. The runner has to grip the handle pulse with both hands, if this function is to work (this data is just for reference and cannot be used as medical data).

The heart rate frequency monitoring system isn't always accurate. Overexertion of organism during training can lead to a serious injury or death. If you start to feel faint, stop the exercise immediately!

BUTTON FUNCTIONS

START: With the power switch on and the safety key in place in the console, press this button and the machine will start.

STOP: Pressing the STOP button during your workout will stop the workout.

SPEED + / -: In the settings mode you can use it to change the parameters of the exercise. When the machine is running, press the button to adjust the speed by 0.1 km at each press. If you press the button for more than 0.5 seconds, the speed will adjust up or down continuously.

EMERGENCY STOP: Press this button to stop the workout immediately if required. Turn the button clockwise to go back to initial state.

SAFETY KEY STOP: In any emergency, pull the safety key rope, and the machine will stop.

To stop/pause the treadmill you can use the START/STOP button on the left handlebar. To change the speed, use the SPEED + / - button on the right handlebar.

RANGE OF SPECIFICATION

	Initial	Initial Data	Set Range	Display Range
TIME (MIN:SECOND)	0:00	/	/	0:00 - 99:59
SPEED (Km/h)	0.3	0.3	0.3 - 6	0.3 - 6
DISTANCE (Km)	0.00	/	/	0.00 - 99.9
CALORIE (THERM)	0	/	/	0 - 999
PULSE (hypo/min)	P	/	/	50 - 200

POWER SAVE FUNCTION

The system is equipped with power saving function. If the treadmill stands idle for 10 minutes, the display will shut down automatically. You can press any button to wake it up again.

TURN OFF

Turn off the power: You can turn the power off to stop the treadmill; it won't be damaged in any way.

CAUTION: We recommend that you maintain a slow speed at the beginning of a session and hold on to the handrails until you become comfortable and familiar with the treadmill.

To end your workout safely, press the STOP button or EMERGENCY STOP button, and the treadmill will stop immediately.

EXERCISE INSTRUCTIONS

1. WARM-UP PHASE

This stage helps get the blood flowing through the body and to get the muscles to work properly. It will also reduce the risk of cramp and muscle injury. It is advisable to do a few stretching exercises as shown below. Each stretch should be held for approximately 30 seconds. Do not force or jerk your muscles into a stretch - if it hurts, STOP.

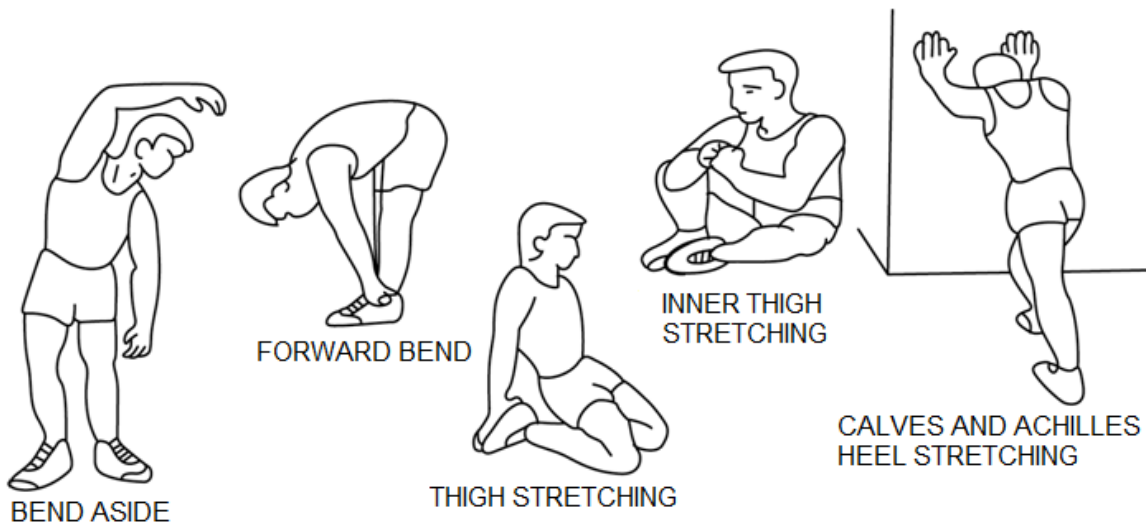

2. EXERCISE PHASE

This is the stage where you put the effort in. After regular use, the muscles in your legs will become stronger. Work as you like but it is very important to maintain a steady tempo throughout. exertion should be sufficient to raise your heart beat into the target zone shown on the graph below.

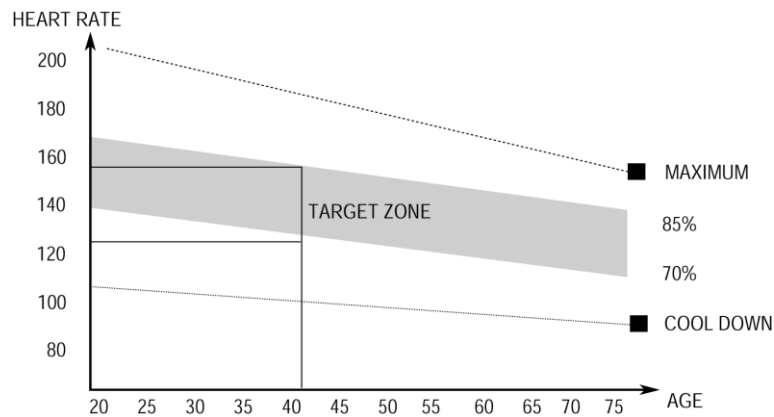

This stage should last for a minimum of 12 minutes although on average it lasts approximately 15 - 20 minutes.

1. COOL-DOWN PHASE

This stage allows your cardio-vascular system and muscles to wind down. This is a repeat of the warm up exercise, e.g. reducing your tempo and continuing for approximately 5 minutes. The stretching exercises should now be repeated, again remember not to force or jerk your muscles into a stretch.

As you get fitter you may need to train longer and harder. It is advisable to train at least three times a week, and if possible space your workouts evenly throughout the week.

MAINTENANCE

Reasonable cleaning/lubricating should be made to extend the longevity of this unit. Performance is maximized when the belt and the mat are kept as clean as possible.

WARNING: THE MAT/DECK FRICTION MAY PLAY A MAJOR ROLE IN THE FUNCTION AND LIFE OF YOUR TREADMILL AND THAT IS WHY WE RECOMMEND YOU CONSTANTLY LUBRICATE THIS FRICTION POINT TO PROLONG THE USEFUL LIFE OF YOUR TREADMILL. FAILING TO DO THIS MAY VOID YOUR WARRANTY.

WARNING: Unplug the power cord before maintenance.

AFTER EACH USE (DAILY)

Clean and inspect the treadmill according to these steps:

- 1) Turn off the treadmill with the on/off switch, then unplug the power cord at the wall outlet.
- 2) Wipe down the running belt, deck, motor cover, and console casing with a damp cloth. Never use solvents, as they can cause damage to the treadmill.
- 3) Inspect the power cord.
- 4) Make sure the power cord is not underneath the treadmill or in any other area where it can become pinched or cut.
- 5) Check the tension and alignment of the running belt. Make sure that the treadmill belt will not damage any other components on the treadmill by being misaligned.

EVERY WEEK

Clean underneath the treadmill, following these steps:

- 1) Turn off the treadmill with the start/stop switch, then unplug the power cord from the wall outlet.
- 2) Fold the treadmill into the upright position, making sure that the lock latch is secure.
- 3) Move the treadmill to a remote location.
- 4) Wipe or vacuum any dust particles or other objects that may have accumulated underneath the treadmill.
- 5) Return the treadmill to its previous position.

EVERY MONTH – IMPORTANT!

- 1) Inspect all the assembly bolts of the machine and check their tightness.
- 2) Turn off the treadmill with the start/stop switch, then unplug the power cord and wait 60 seconds.
- 3) Remove the motor cover. Wait until ALL LCD lights turn off.
- 4) Clean the motor and lower board area to eliminate any lint or dust particles that may have accumulated. Failure to do so may result in premature failure of key electrical components.

EVERY 6 MONTHS

It may be necessary to lubricate your treadmill running deck at least once every six months to maintain optimal performance.

- 1) Turn off the treadmill with the start/stop switch, and then unplug the power cord at the wall outlet.
- 2) Loosen both the rear roller bolts. (For best results, place two removable marks on both sides of the frame and note roller position). Once the belt is loosened, take the bottle of lubricant and apply it to the entire top surface of the running deck. Tighten both rear roller bolts (matching up the marks for proper position) to original position. After you have applied the lubricant, plug in the power cord, insert the safety key, start the treadmill and walk on the belt for two minutes to spread the lubricant.
- 3) Lubricate the air shocks with Teflon-based spray.

EVERY 2 YEARS

It is necessary that you replace your treadmill motor brushes, motor V-belt and the running belt once every 2 years to avoid damaging your treadmill. If you fail to replace these components and the treadmill gets damaged, the warranty will not apply.

SERVICING: IF YOU FAIL TO COMPLY WITH OUR FITNESS' MAINTENANCE AND SERVICING STEPS ABOVE, YOU MAY VOID YOUR WARRANTY. IF YOU REQUIRE A SKILLED FITNESS

REPRESENTATIVE TO UNDERTAKE ONE OF THE STEPS ABOVE, PLEASE CALL OR EMAIL US.

GENERAL CLEANING

- 1) Use a soft, damp cloth to wipe the edge of the belt and the area between the belt edge and the frame. A mild soap and water solution along with a nylon scrub brush will clean the top of the textured belt. This task should be done once a month. Allow it to dry before using it.
- 2) On a monthly basis, vacuum underneath your treadmill to prevent dust build-up. Once a year, you should remove the black motor shield and vacuum out any dirt that may accumulate.

GENERAL CARE

- 1) Check parts for wear before use.
- 2) Pay particular attention to the fixing knobs and make sure they are tight.
- 3) Always replace the mat if worn and any other defective parts.
- 4) If in doubt do not use the treadmill and contact our helpline.

TAKE CARE TO PROTECT CARPETS AND FLOOR IN CASE OF A LEAKAGE – WE RECOMMEND USING A PROTECTION PAD UNDER THE TREADMILL. This product is a machine that contains moving parts which have been greased/lubricated and could leak.

BELT/DECK/ROLLER LUBRICATION

The mat/deck friction may play a major role in the function and life of your treadmill and that is why we recommend you constantly lubricate this friction point to prolong the longevity of your treadmill.

You should apply the lubrication after approximately the first 20 hours of operation. We recommend lubrication of the deck every 30 days.

RUNNING BOARD LUBRICATION

The treadmill is equipped with lubricated running board, which needs constant maintenance. The friction between running board and running belt has a great effect on the treadmills' life. So please lubricate your machine regularly. The steps are thus:

- a) Cut off the power.
- b) Wipe off the dust between the running board and the running belt with a clean cloth.
- c) Daub the silicon oil on the running board and the running belt evenly.
- d) While adding lubrication oil, please keep your clothes away from the machine to avoid injury.

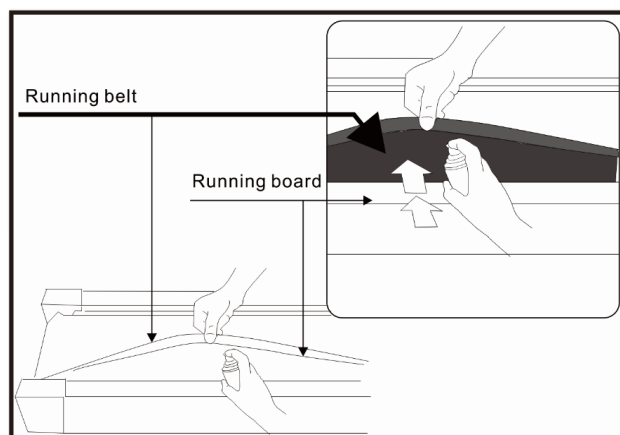

See below procedures for lubricating:

- 1) Use a soft, dry cloth to wipe the area between the belt and the deck.

- 2) Spread the lubricant onto the inside surface of the belt and the deck evenly (make sure the machine is turned off and power is disconnected).
- 3) Periodically lubricate the front and rear rollers to keep them at their peak performance. If the treadmill belt/deck/roller is kept reasonably clean, you'll further the treadmill's longevity.

How to check the running mat for proper lubrication:

- 1) Disconnect the main power supply.
- 2) Fold the treadmill up into the storage position.
- 3) Feel the back surface of the running mat.

If the surface is slick when touched, then no further lubrication is needed.

If the surface is dry to the touch, apply a suitable silicone lubricant.

We recommend you use a silicone based spray to lubricate your treadmill. This can be purchased from your local sports retailer or a local hardware store.

TIGHTENING THE BELT/POLY V-BELT

Identification ways for the degree of tightness of running belt and poly V-belt:

When the running belt skips, please follow the steps as follows to make sure which belt needs to be adjusted - running belt or poly V-belt.

- a) Cut off power, screw off the bolt on the protective cover. Then take down the protecting cover from the treadmill.
- b) Turn the speed to approximately 3 km/h, step on the running belt and try your best to make the running belt stop. If the running belt stops together with the front roll, but the motor still runs, it means the poly V-belt needs to be adjusted.
- c) Turn the speed to be around 3 km/h, step on the running belt and try your best to make the running belt stop. If the running belt stops, but the front roller still runs, it means the running belt needs to be adjusted.

THE ADJUSTMENT STEPS FOR POLY V-BELT

- a) Cut off power firstly and take down the protective cover.
- b) Loosen/tighten the motor screws.
- c) Connect the treadmill to the power supply, and check, whether the poly V-belt is loose. If it is, repeat the precious steps.

CENTERING THE RUNNING BELT

DO NOT OVERTIGHTEN the walking belt. This may cause reduced motor performance and excessive roller wear.

To centre the walking belt:

- Place treadmill on a level surface.
- Run the treadmill at approximately 3.5 mph.
- If the belt has drifted to the right, turn the right adjusting bolt 1/2 turn clockwise and the left adjusting bolt 1/2 turn counter clockwise
- If the belt has drifted to the left, turn the left adjusting bolt 1/2 turn clockwise and the right adjusting bolt 1/2 turn counter clockwise.

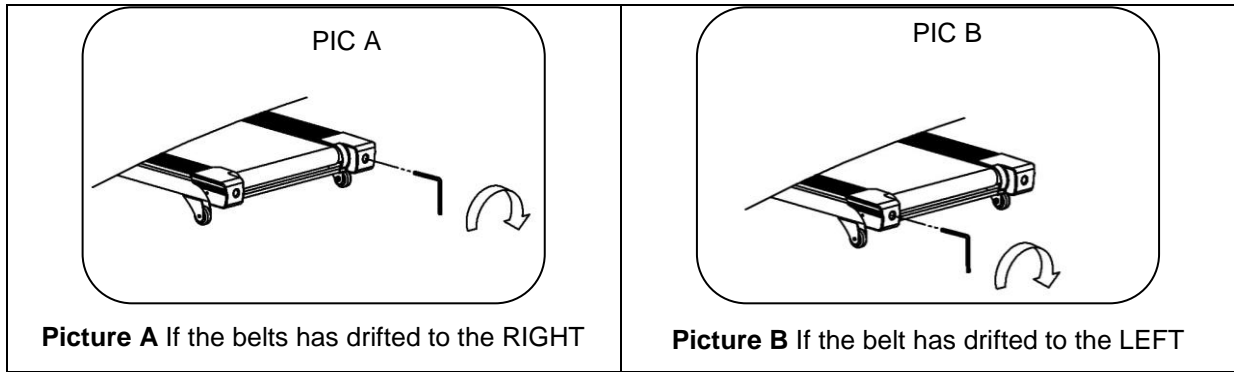

WARNING: ALWAYS UNPLUG THE TREADMILL FROM THE ELECTRICAL OUTLET BEFORE CLEANING OR SERVICING THE UNIT.

EXPLODED DRAWING

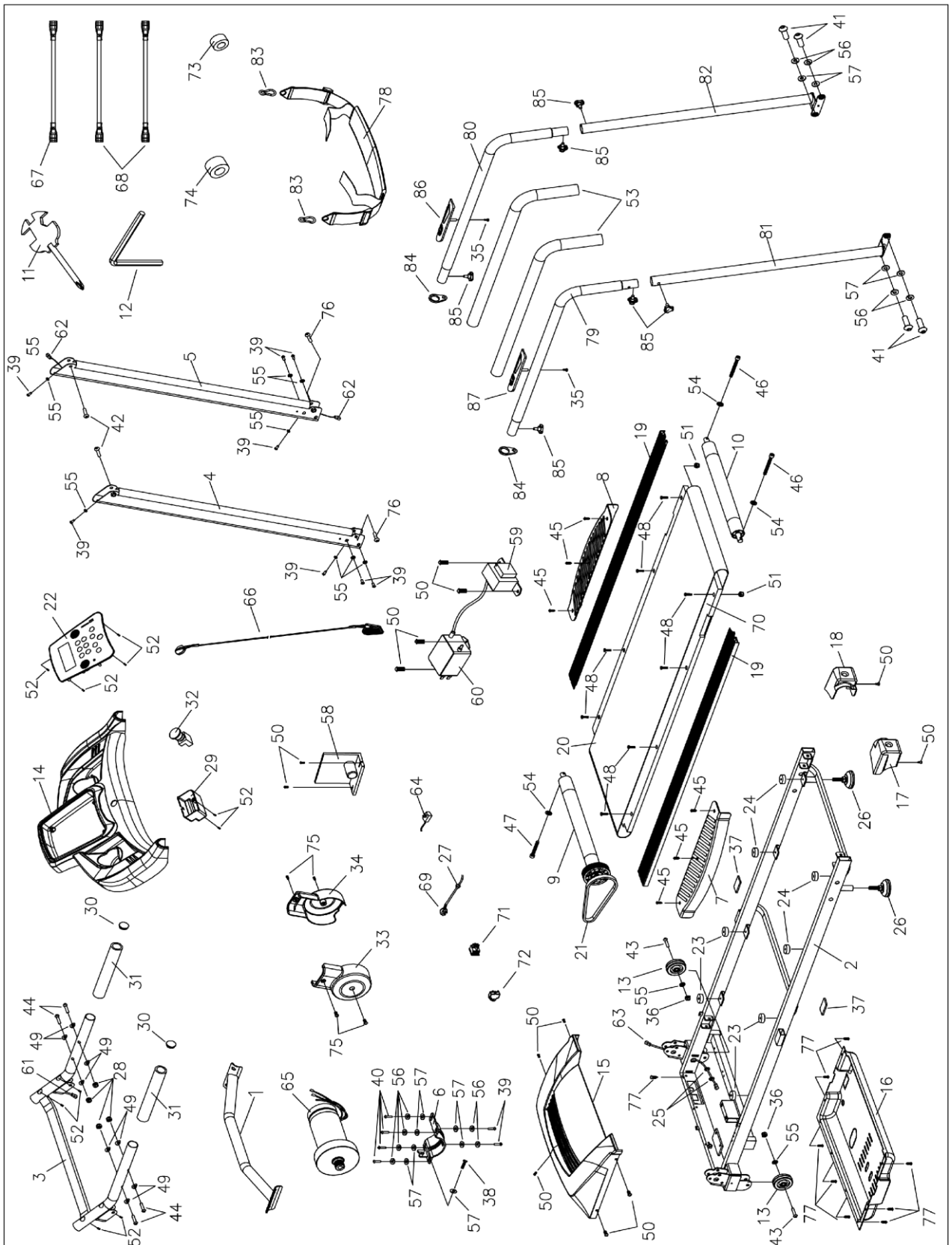

PARTS LIST

NO.	DESCRIPTION	SPECIFICATION	QTY.
1	Connecting tube		1
2	Main Frame		1
3	Computer Bracket		1
4	Left Upright		1
5	Right Upright		1
6	Motor Bracket		1
7	Left foot pedal		1
8	Right foot pedal		1
9	Front Roller		1
10	Rear Roller		1
11	Wrench w/ screw driver	S=13, 14, 15	1
12	5# Allen Wrench	5 mm	1
13	Adjustable wheel		2
14	Console top cover		1
15	Motor top cover		1
16	Motor bottom cover		1
17	Left rear cover		1
18	Right rear cover		1
19	Side rail		2
20	Running belt		1
21	Motor belt		1
22	Computer panel		1
23	Blue cushion		4
24	Square cushion		4
25	Ring protecting wire plug		2
26	Foot pad		2
27	Power wire buckle		1
28	Nut		4
29	Power on/off cover		1
30	End cap		2
31	Foam		2
32	Emergency Stop Button		1
33	Left side cover		1
34	Right side cover		1
35	Screw	ST4.2*20	2

36	Nut	M8	2
37	EVA cushion		2
38	Bolt	M8*35	1
39	Bolt	M8*15	10
40	Bolt	M8*20	4
41	Bolt	M8*25	4
42	Bolt	M8*38	2
43	Bolt	M8*40	2
44	Bolt	M8*50	4
45	Screw	ST4.2*15	6
46	Bolt	M6*55	2
47	Bolt	M6*45	1
48	Bolt	M6*35	8
49	Arc washer	8	8
50	Screw	M5*8	13
51	Nut	M6	2
52	Screw	ST4.2*12	10
53	Handlebar foam		2
54	Washer	6	3
55	Washer	8	10
56	Washer	8	11
57	Washer C	8	9
58	Control board		1
59	Inductor	Optional	1
60	Filter	Optional	1
61	Console upper wire		1
62	Console middle wire		1
63	Console lower wire		1
64	Speed sensor		1
65	DC Motor		1
66	Safety accessory		1
67	AC single line	Blue	1
68	AC single line	Brown	2
69	Power wire		1
70	Running board		1
71	Square switch		1
72	Overload Protector		1
73	Magnetic ring		1

74	Magnetic core		1
75	Screw	M5*12	4
76	Bolt	M8*35	2
77	Screw	ST4.2*12	9
78	Safety band	Optional	1
79	Left handle bar		1
80	Right handle bar		1
81	Left support tube		1
82	Right support tube		1
83	Safety band hook	Optional	2
84	Hook		2
85	Triangle bolt	M6*10	6
86	Handpulse with speed		1
87	Handpulse with start/stop		1

TROUBLE SHOOTING

1. There is no display on screen after the machine is connected to the power source:

- a. Please check the overload button, if the overload protector button bounces, please press it down again;
- b. Please make sure the power source, overload protector, the driver and the transformer are connected well;
- c. Please make sure the wires from the driver to the computer board are connected well.

2. E01 display: Unable to relay signal from the computer board to the driver

- a. Please check the wire from the drive to the computer board, if the wire is broken, please change a new one.
- b. Please check the electronic parts in computer board, if it is wrong, change a new one.
- c. Change a new transformer.

3. E02 display: Anti-explosion protection or a problem with the motor

- a. Please check the wire from the motor and connect it well. If this is not a problem with wire connection, please replace the motor.
- b. If there is a bad smell from the control board, or if the IGBT has short-circuited, please change a new driver.
- c. Please make sure the voltage is in normal condition.

4. E03 display: No signal

- a. If the E03 is displayed 5 to 8 seconds after the start, there is no signal. Please check the connection of the sensor. If it is not connected well, try to connect it again. If the sensor does not work well, replace it.
- b. The control board signal is wrong, please replace the driver.

5. E05 display: Over load current protect

- a. If the the current is too strong, the system will automatically shut down to protect itself. Please restart the machine.
- b. It's possible part of the machine is blocked and causing a problem with the moto. Please add the oil to the machine and restart.
- c. Please check if there is bad smell from the motor. If there is, replace the motor.
- d. Please check if there is bad smell from the driver. If there is, replace the driver.

TERMS AND CONDITIONS OF WARRANTY, WARRANTY CLAIMS

General Conditions of Warranty and Definition of Terms

All Warranty Conditions stated hereunder determine Warranty Coverage and Warranty Claim Procedure. Conditions of Warranty and Warranty Claims are governed by Act No. 40/1964 Coll. Civil Code, Act No. 513/1991 Coll., Commercial Code, and Act No. 634/1992 Coll., Consumer Protection Act, as amended, also in cases that are not specified by these Warranty rules.

The seller is SEVEN SPORT s.r.o. with its registered office in Borivojova Street 35/878, Prague 13000, Company Registration Number: 26847264, registered in the Trade Register at Regional Court in Prague, Section C, Insert No. 116888.

According to valid legal regulations it depends whether the Buyer is the End Customer or not.

“The Buyer who is the End Customer” or simply the “End Customer” is the legal entity that does not conclude and execute the Contract in order to run or promote his own trade or business activities.

“The Buyer who is not the End Customer” is a Businessman that buys Goods or uses services for the purpose of using the Goods or services for his own business activities. The Buyer conforms to the General Purchase Agreement and business conditions to the extent specified in the Commercial Code.

These Conditions of Warranty and Warranty Claims are an integral part of every Purchase Agreement made between the Seller and the Buyer. All Warranty Conditions are valid and binding, unless otherwise specified in the Purchase Agreement, in the Amendment to this Contract or in another written agreement.

Warranty Conditions

Warranty Period

The Seller provides the Buyer a 24 months Warranty for Goods Quality, unless otherwise specified in the Certificate of Warranty, Invoice, Bill of Delivery or other documents related to the Goods. The legal warranty period provided to the Consumer is not affected.

By the Warranty for Goods Quality, the Seller guarantees that the delivered Goods shall be, for a certain period of time, suitable for regular or contracted use, and that the Goods shall maintain its regular or contracted features.

The Warranty does not cover defects resulting from:

- User's fault, i.e. product damage caused by unqualified repair work and improper assembly
- Improper maintenance
- Mechanical damages
- Regular use (e.g. wearing out of rubber and plastic parts, joints etc.)
- Unavoidable event, natural disaster
- Adjustments made by unqualified person
- Improper maintenance, improper placement, damages caused by low or high temperature, water, inappropriate pressure, shocks, intentional changes in design or construction etc.

Warranty Claim Procedure

The Buyer is obliged to check the Goods delivered by the Seller immediately after taking the responsibility for the Goods and its damages, i.e. immediately after its delivery. The Buyer must check the Goods so that he discovers all the defects that can be discovered by such check.

When making a Warranty Claim the Buyer is obliged, on request of the Seller, to prove the purchase and validity of the claim by the Invoice or Bill of Delivery that includes the product's serial number, or eventually by the documents without the serial number. If the Buyer does not prove the validity of the Warranty Claim by these documents, the Seller has the right to reject the Warranty Claim.

If the Buyer gives notice of a defect that is not covered by the Warranty (e.g. in the case that the Warranty Conditions were not fulfilled or in the case of reporting the defect by mistake etc.), the Seller is eligible to require a compensation for all the costs arising from the repair. The cost shall be calculated according to the valid price list of services and transport costs.

If the Seller finds out (by testing) that the product is not damaged, the Warranty Claim is not accepted. The Seller reserves the right to claim a compensation for costs arising from the false Warranty Claim.

In case the Buyer makes a claim about the Goods that is legally covered by the Warranty provided by the Seller, the Seller shall fix the reported defects by means of repair or by the exchange of the damaged part or product for a new one. Based on the agreement of the Buyer, the Seller has the right to exchange the defected Goods for a fully compatible Goods of the same or better technical characteristics. The Seller is entitled to choose the form of the Warranty Claim Procedures described in this paragraph.

The Seller shall settle the Warranty Claim within 30 days after the delivery of the defective Goods, unless a longer period has been agreed upon. The day when the repaired or exchanged Goods is handed over to the Buyer is considered to be the day of the Warranty Claim settlement. When the Seller is not able to settle the Warranty Claim within the agreed period due to the specific nature of the Goods defect, he and the Buyer shall make an agreement about an alternative solution. In case such agreement is not made, the Seller is obliged to provide the Buyer with a financial compensation in the form of a refund.



SEVEN SPORT s.r.o.

Registered Office:	Borivojova 35/878, 130 00 Praha 3, Czech Republic
Headquarters:	Delnicka 957, 749 01 Vitkov, Czech Republic
Warranty & Service Centre:	Cermenska 486, 749 01 Vitkov, Czech Republic
CRN:	26847264
VAT ID:	CZ26847264
Phone:	+420 556 300 970
E-mail:	eshop@insportline.cz reklamace@insportline.cz servis@insportline.cz
Web:	www.insportline.cz

SK

INSPORTLIN s.r.o.

Headquarters, Warranty & Service centre:	Elektricka 6471, 911 01 Trenčin, Slovakia
CRN:	36311723
VAT ID:	SK2020177082
Phone:	+421(0)326 526 701
E-mail:	objednavky@insportline.sk reklamacie@insportline.sk servis@insportline.sk

Web: www.insportline.sk

Date of Sale:

Stamp and Signature of Seller: